

REED SWITCHES

UL / CSA / ETL listed

		NORMALLY OPEN									
		SUBMINIATURE					MINIATURE				
S.T.G.-Type		2314	2317	2211	2212	9215	2722	2725	2715	2717	
OKI-Type				ORD 2211	ORD 2212	ORD 9215					
Contact form		A	A	A	A	A	A	A	A	A	
Contact material		Rh	Rh	Rh	Rh	Rh	Rh	Rh	Rh	Rh	
Switching capacity	max. W/VA	10	10	50	10	10	10	10	10	10	
Switching voltage	max. V AC/DC	400	470	100	100	100	230	230	350	500	
Switching current	max. A	0,5	0,5	0,5 in-rush 3A	0,2	0,4	0,5	0,5	0,5	0,5	
Carrying current	max. A	1,0	1,0	2,5	0,5	1,0	1,0	1,0	1,0	1,0	
Dielectric strength	min. VDC	600	700	150	120	150	400	400	600	1000	
Contact resistance	max. mΩ	150	150	100	100	100	100	100	100	100	
Insulation resistance	min. Ω	10 ¹¹	10 ¹¹	10 ⁹	10 ⁹	10 ⁹	10 ¹¹	10 ¹¹	10 ¹¹	10 ¹¹	
Pull-in sensitivity	AT	15...35	15...35	20...60	15...45	10...50	20...50	20...50	20...50	20...50	
Drop-out sensitivity	min. AT	5	5	8	DO/PI>0,8	4	5	5	10	5	
Switching time without bounce	max. ms	1,8	1,8	0,6	0,4	0,4	2,0	2,0	2,0	2,0	
Bounce time	max. ms	0,2	0,2	0,4	1,0	0,4	0,5	0,5	1,0	0,5	
Release time	max. ms	0,05	0,05	0,05	0,05	0,05	0,10	0,10	0,10	0,10	
Resonant frequency	typ. Hz	5000	5000	4600	3900	3700	2900	2900	2900	2900	
Operating frequency	max. Hz	200	200	500	500	500	200	200	230	200	
Vibration	20 g Hz	35g/2000	35g/2000	10-1000	10-1000	10-1000	35g/2000	35/2000	2000	2000	
Shock	11 ms g	50	50	30	30	30	50	50	50	50	
Capacitance	typ. pF	0,7	0,7	0,5	0,5	0,3	0,5	0,5	0,5	0,5	
Operating temperature range	°C	-40...+150			-40...+125			-40...+150			
Test coil	Type	1035	1035	0221	0221	0221	1700	1700	1700	1700	
Features		Miniature, high power	Miniature, high power	Lamp load	Close differential typ, low sound	General purpose, miniature type	High power, wide differential	High power	High power	High breakdown voltage	

Dimensions

Total length	A max. mm	55,0	55,0	45,0	45,0	45,0	55,0	55,0	55,0	55,0
Glass length	B max. mm	14,1	14,1	16,5	16,5	17,0	19,0	19,0	19,0	19,0
Glass diameter	C max. mm	2,3	2,3	2,8	2,8	2,8	2,6	2,6	2,6	2,6
Wire diameter	D max. mm	0,50	0,50	0,6	0,35x0,6	0,5	0,55	0,55	0,55	0,55

Additional types on request

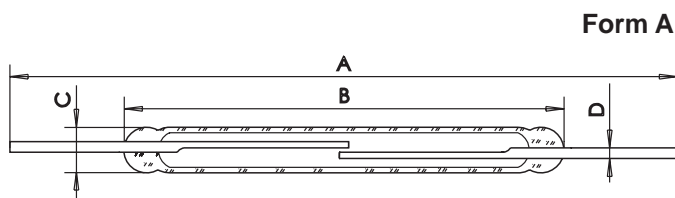

The materials used for Reed Switch magnets are generally ALNICO (an aluminium nickel cobalt alloy), a ceramic (barium ferrite or another metal oxide) or rare earth magnets. Due to their specific magnetic characteristics, the types of magnets differ in shape: ALNICO magnets are bar magnets with a length/diameter ratio of 3/1 to 5/1; oxide magnets are generally disc or moulded magnets. Also important to note is the difference in temperature coefficient:
ALNICO: 0.02 %/K, oxide: 0.2 %/K

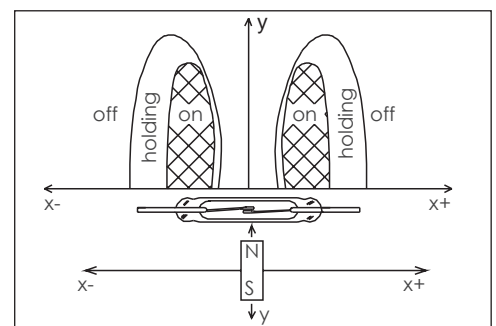
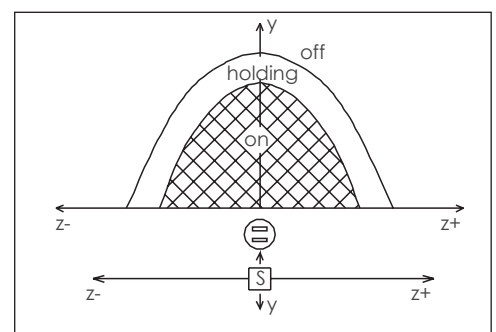
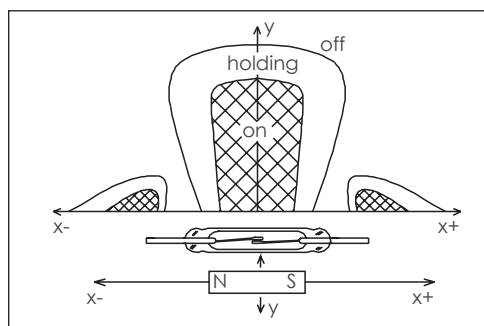

ELECTROSÓN