

## 2.1

### Solenoid interlocks AZM 161 range



#### Features

- Thermoplastic enclosure
- Manual and emergency release
- Long life
- Double insulated □
- High holding force 2,000 N
- 30 N latching force
- Wiring compartment
- Actuation on de-energisation or energisation
- 3 cable entries
- Actuating play 5.5 mm in direction of actuation

#### Voltage variants

- 24 VAC/DC
  - 110 VAC/DC
  - 230 VAC/DC
- Always state required supply voltage when ordering

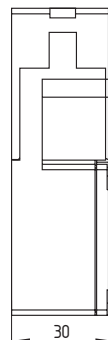
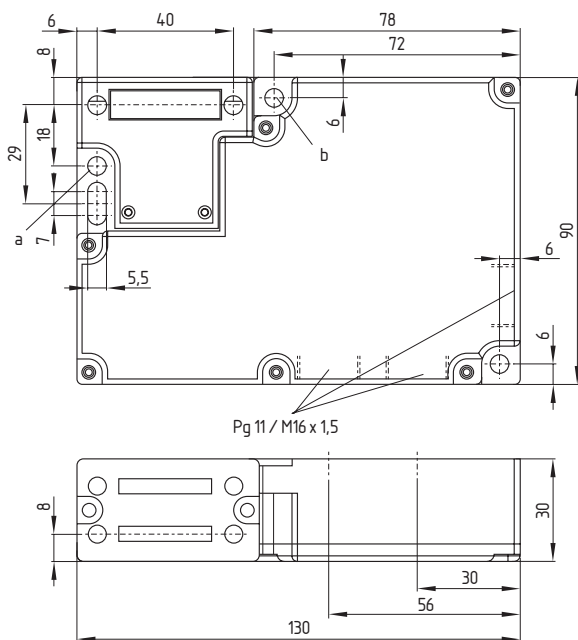

#### Manual release

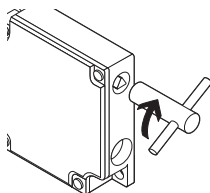

- For manual release using M5 triangular key, available as accessory
- For maintenance, setting-up, etc.

#### Emergency release

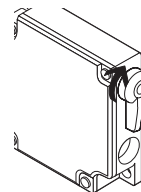

- For cases of danger
- Fitting only within the guarded area

#### Approvals



# ELECTROSÓN

## 2. Solenoid interlocks

### 2.1 AZM 161 range



**Info** The applicable ordering suffix is added at the end of the part number of the interlock.

- Available with connector on enquiry
- With M 16 x 1.5 cable entry, ordering suffix -M16

#### Actuation on de-energisation

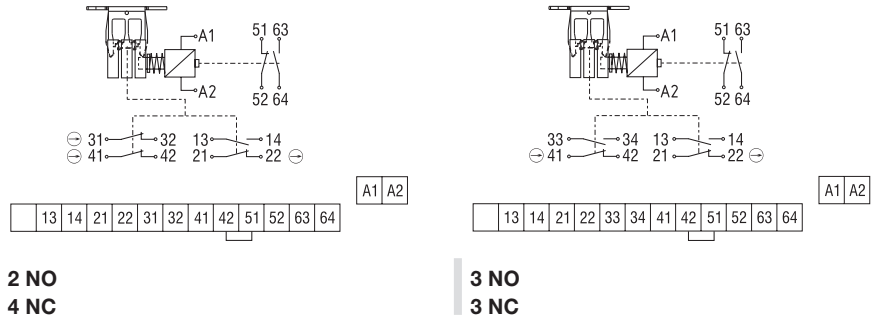

#### Contacts/ Switch travel

With screw terminals  
With cage clamps

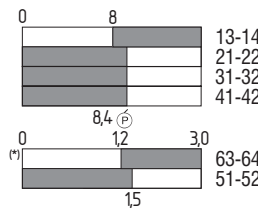

**AZM 161SK-24rk**  
**AZM 161CC-24rk**

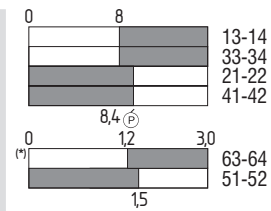

**AZM 161SK-33rk**  
**AZM 161CC-33rk**

#### Actuation on energisation

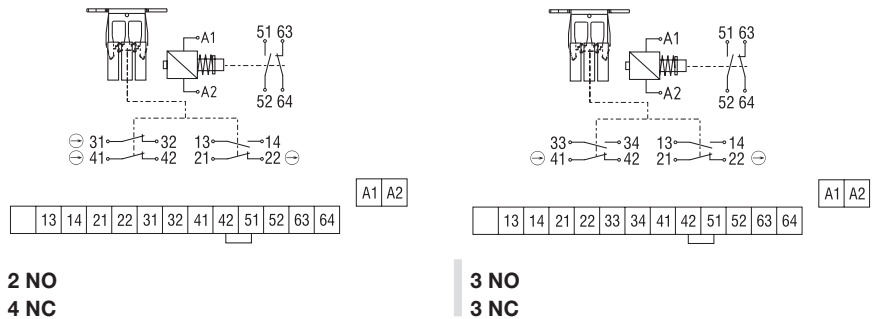

#### Contacts/ Switch travel

With screw terminals  
With cage clamps

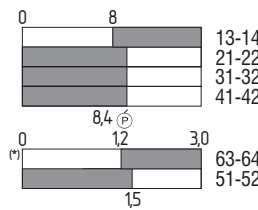

**AZM 161SK-24rka**  
**AZM 161CC-24rka**

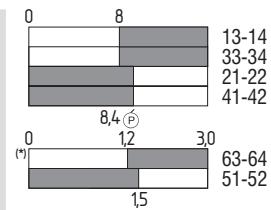

**AZM 161SK-33rka**  
**AZM 161CC-33rka**

#### Notes

(\*) The contacts 51-52 and 63-64 are solenoid locking principle or de-energisation of the coil A1-A2. Circuit diagrams show de-energised condition with actuator inserted (0 in switch travel diagram). Interlocks with actuation on energisation may only be used in special cases after a thorough evaluation of the accident risk, since the guarding device can immediately be opened on failure of the electrical power supply or when the main switch is opened. Actuators must be ordered separately. A selection of suitable actuators can be found in 2.2.



### Straight actuator AZM 161-B1

- On hinged guards, minimum actuating radius 180 mm at 90° to the plane of the actuator
- Similarly, minimum actuating radius 150 mm in line with the plane of the actuator



- The axis of the hinge should be 5 mm above the top edge of the solenoid interlock and in the same plane

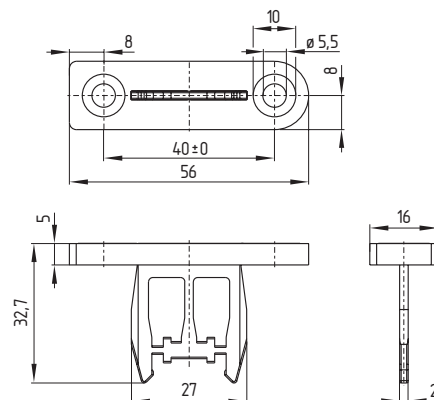

### Straight actuator AZM 161-B1E

- On hinged guards, minimum actuating radius 180 mm at 90° to the plane of the actuator
- Similarly, minimum actuating radius 150 mm in line with the plane of the actuator



- The axis of the hinge should be 5 mm above the top edge of the solenoid interlock and in the same plane
- Mounting details as for AZM 160-B1S

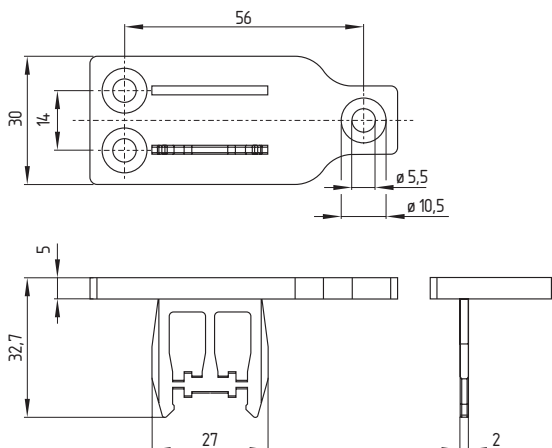

### Adjustable actuator AZM 161-B6

- Adjustable actuator for very small actuating radii.
- On hinged guards, minimum actuating radius 95 mm at 90° to the plane of the actuator, adjustable using an hexagonal key wrench 2.5 mm A/F (b)
- Similarly, minimum actuating radius 95 mm in line with the plane of the actuator, adjustable using an hexagonal key wrench 2.5 mm A/F (a)



- The axis of the hinge should be 11 mm above the top edge of the solenoid interlock and in the same plane

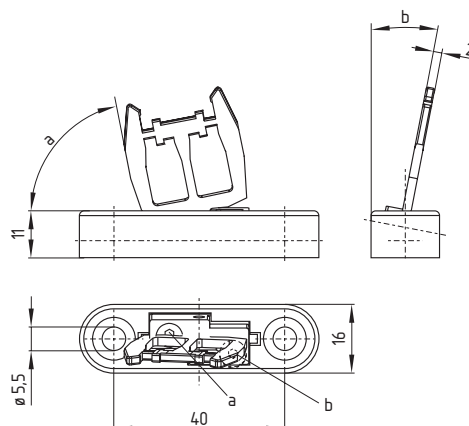



### Tamperproof screws



**Screw lengths**

Countersunk-head screws with unidirectional slots

- M 5 x 12, Id. No.: 402 530 3000
- M 5 x 16, Id. No.: 402 530 3001
- M 5 x 20, Id. No.: 402 530 3002

Supplied in sets of 2 screws

- To mount the actuator
- Higher protection against tampering with interlock
- Protect against unauthorised removal of actuator
- Available in various lengths

### Slot sealing plug AZM 161

- To cover unused actuator slots
- For protection against the ingress of coarse dirt
- Simple clip-in fitting
- Quantity required: 3 per interlocking device

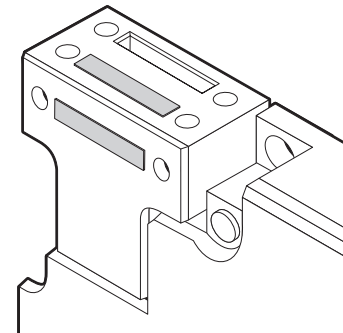

**2.**  
**2.3**

**Solenoid interlocks**  
**Accessories**



**Mounting set MS AZM 161**

- For simple mounting on profile systems
- Mounting of the solenoid interlock parallel or right-angled to the safety guard

**Hinweis**

- The mounting sets can only be used in conjunction with actuator AZM 161-B6.
- Solenoid interlock and actuator are **not included** in delivery.

**Legend**

- 1 Roundhead screw M5 x 16 per ISO 7380
- 2 Washer per DIN 125-5,3
- 3 Counter sunk screw M5 x 16 per DIN 7991
- 4 Mounting plate AZ 16/AZM 161
- 5 U-profile AZM 161
- 6 Mounting angle AZM 161
- 7 Roundhead screw M5 x 10 per ISO 7380

**Not provided:**

- 8 Solenoid Interlock AZM 161
- 9 Actuator AZM 161-B6

**MS AZM 161 P**

Mounting parallel to safety guard

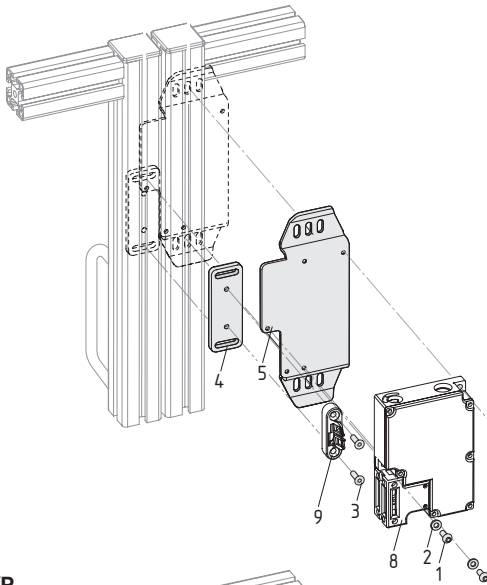

**MS AZM 161 R/P**

Mounting right-angled to safety guard

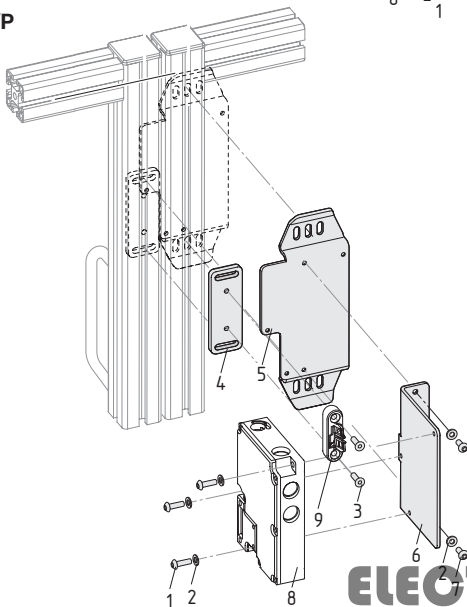

**Mounting plate**  
**AZ 16/AZM 161**

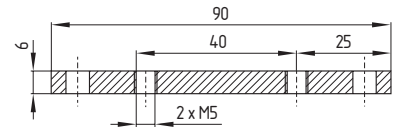
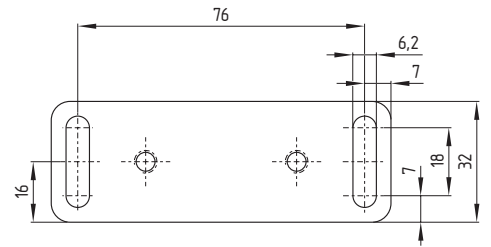

**U-profile**  
**AZM 161**

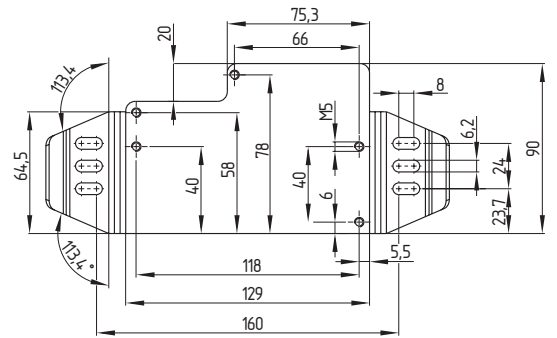
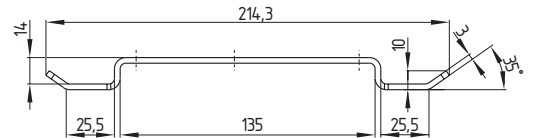

**Mounting angle**  
**AZM 161**

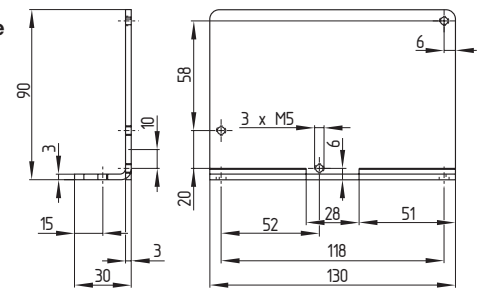

## 2. Solenoid interlocks

### 2.27 Technical data



	AZM 161	AZM 170 AZM 170i AZM 170 SK	AZM 170-ST AZM 170i-ST
Standards:	IEC/EN 60947-5-1/DIN VDE0660-200; EN 1088; BG-GS-ET-19		
Enclosure material:	Glass-fibre reinforced thermoplastic, self-extinguishing		
Actuator and latching bolt:	Stainless steel 1.4301		
Protection class:	IP 67 to IEC/EN 60529/DIN VDE 0470-1		
Contact material:	Silver		
Contact type:	Changeover with double break Zb, or 2 NC or 3 NC or 4 NC contacts, with galvanically separated contact bridges		Changeover with double break Zb, with galvanically separated contact bridges
Switching system:	⊖ IEC 60947-5-1; ⊕ BG-GS-ET-19; slow action, NC contacts with positive break		
Termination:	Screw terminals or cage clamps max. 1.5 mm <sup>2</sup> (incl. conductor ferrules)	Cut clamp terminals (IDC method) 0.75 ... 1.0 mm <sup>2</sup> flexible Ordering suffix SK: Screw terminals 1.5 mm <sup>2</sup> flexible	Connector M 12 x 1, four pole
Rated impulse withstand voltage U <sub>imp</sub> :	4 kV		
Rated insulation voltage U <sub>i</sub> :	250 V		
Thermal test current rating I <sub>th</sub> :	10 A		
Utilisation category:	AC-15; DC-13	AC-15	
Rated operating current/voltage I <sub>e</sub> /U <sub>e</sub> :	2.5 A/24 VDC; 4 A/230 VAC		4 A/230 V
Max. fuse rating:	6 A gL/gG D-fuse		
Positive break travel:	8.8 mm	11 mm	
Positive break force:	10 N for each NC contact fitted (depending on the setting of the ball latch)	6 N for each NC contact fitted	
Solenoid duty rating:	Continuous operation		
Rated control voltage U <sub>S</sub> :	24 VAC/DC or 110 VAC/DC, 50/60 Hz or 230 VAC/DC, 50/60 Hz	24 VAC/D or 110 VAC/DC, 50/60 Hz or 230 VAC/DC, 50/60 Hz	
Consumption:	Max. 10 W		
Ambient temperature:	- 25 °C ... + 60 °C		
Mechanical life:	> 1 million operations		
Holding force F <sub>max</sub> :	2,000 N	1,000 N	
Holding force of integral ball latch:	-		
Latching force:	30 N for Ordering Suffix r		



# ELECTROSÓN