



Description

The AZM161 Series is designed for machines/work cells where access to a hazardous work area must be controlled until safe conditions exist. Their solenoid-latching feature permits locking a machine guard until dangerous conditions, which may exist immediately after removal of power, have abated. Solenoid-latching may be controlled by a time delay, motion detector, position sensor or other suitable component.

The unit features independent actuator key (guard) position and solenoid-latching monitoring contacts. These permit the prevention of machine restart until the guard is closed **and** the solenoid-latching pin is in the locked position.

The AZM161 consists of an electromechanical safety interlock switch with “positive-break” contacts and a locking actuator key. In addition, the solenoid mechanism features a NO and a NC solenoid-latching monitoring contact, and an auxiliary manual unlocking device ... the latter provided to aid in installation and for use in the event of a power failure (when using the “unlocking by solenoid” model).

Operation

The AZM161 electromechanical safety interlock switch assembly consists of a rugged switch-solenoid-latching mechanism and a geometrically-unique locking actuator key. The switch actuating key is typically mounted to a movable machine guard.

When the guard is closed, the actuating key is held in position by the solenoid-latching mechanism. The guard may only be opened by energizing or de-energizing (depending upon model) the solenoid-latching mechanism.

Upon opening of the guard, the switch’s “positive-break” NC contacts are forced to open through a direct (non-resilient) mechanical linkage with the actuating key. The NO contacts close upon key removal.

The solenoid-latching mechanism circuit features a NO and a NC contact which permit monitoring its status. This NC contact is wired in series with the NC contact in the safety switch circuit. Thus the machine is prevented from starting until the actuating key is inserted (guard is closed) and the solenoid has locked it in the closed position.

Features & Benefits

- **Solenoid-locking design** ... controls access to hazardous areas until safe conditions exist.
- **Highly tamper-resistant** ... difficult to defeat with simple tools, tape, bent wires, etc. Reduces liability exposure.
- **“Positive-break” NC contacts** ... assure circuit interruption upon actuator key removal.
- **Conditional “safe” outputs** ... actuating key must be fully inserted and solenoid must be actuated to lock key before “closed” safety signal is provided.
- **Watertight design** ... meets IP67 environmental requirements.
- **High-strength, stainless-steel actuator key** ... tolerates mechanical abuse without damage.
- **Rugged, corrosion-resistant housing** ... tolerates hostile environments.
- **Four optional key entry locations** ... provide installation flexibility.
- **Independent actuator key position and locking pin position monitoring contacts** ... provide a higher degree of safety.
- **Available in “solenoid-locking” and “solenoid-unlocking” models** ... for application versatility.
- **Meets rigid safety agency standards** ... IEC, BG and VDE (UL and CSA pending).
- **Wide selection of accessories** ... to meet diverse application requirements.

Typical Applications



The AZM161 is intended for use as a safety interlock switch on movable machine guards which must not be opened until dangerous conditions, which may exist after the removal of power, have abated. Such conditions are flywheel overrun, spindle momentum, unstable rest positions, etc. Typical applications are textile machines, stamping presses, articulating robot arms, mixing machines, metal working equipment, printing presses and packaging machinery.

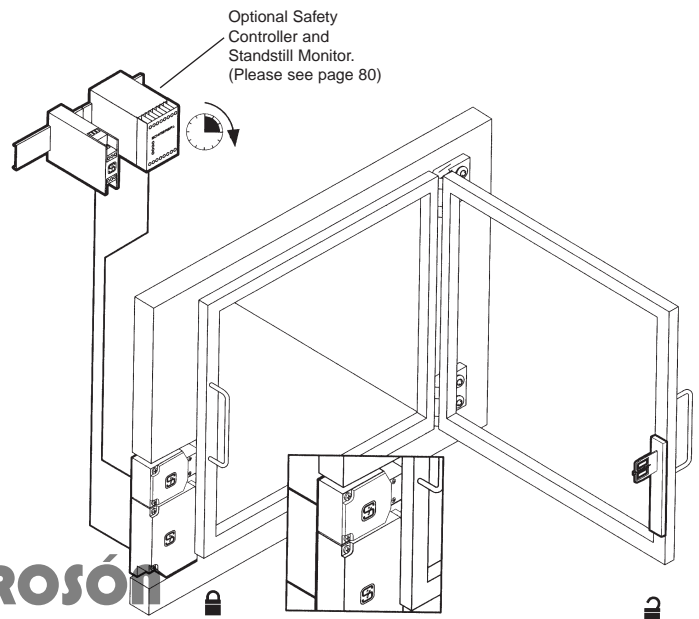

AZM161 AVAILABLE MODELS AND ACCESSORIES

AVAILABLE STANDARD MODELS (Includes 1/2" NPT Plastic Adapter. Actuator key sold separately)

Part Number	Contacts	Description
AZM161SK-24rk-*	2NO & 4 NC	Actuating key locked by spring and unlocked by energizing solenoid.
AZM161SK-33rk-*	3NO & 3 NC	
AZM161SK-12/12rk-**	2NO & 4 NC	
AZM161SK-24rka-*	2NO & 4 NC	Actuating key locked by energizing solenoid and unlocked by spring. (See Note 1 below)
AZM161SK-33rka-*	3NO & 3 NC	
AZM161SK-12/12rka-**	2NO & 4 NC	

*Please specify solenoid operating voltage via addition of one of the following suffix codes:

Voltage	Add Suffix
24VAC/DC	-24VAC/DC
115VAC	-115VAC
230VAC	-230VAC

**Please specify solenoid operating voltage via addition of one of the following suffix codes:

Voltage	Add Suffix
24VAC/DC	-24VAC/DC
110/230VAC	-110/230VAC

Example: AZM161SK-24rk-24VAC/DC

Note 1: Use of this model permits the guard to be opened in the event of a power failure. Generally accepted safety standards/practices suggest this model only be used after conducting a thorough risk evaluation in the context of the application.

POSITIVE-BREAK is a trademark of SCHMERSAL

AVAILABLE KEYS & ACCESSORIES for AZM161 Keyed-Interlock Switches

Part Number	Description
AZM161-B1	Standard actuating key
AZM161-B1E	Standard actuating key with heavy-duty mounting bracket
AZM161-B6	Small radius actuating key
AZM161-B6-2177	Funnel entry adapter with elongated flexible-movement actuating key
AZM-Key	Solenoid-latch bypass key
M20-CG	Cord grip (cable gland)
M20-1/2"P	Plastic 1/2" NPT adapter (two supplied with basic unit)
M20-1/2"M	Metal 1/2" NPT adapter
PL-M20-24V	24VAC/DC pilot light kit
PL-M20-120V	120VAC/DC pilot light kit
Add suffix -1637 to basic part number	Gold contacts
MS AZM 161	Adjustable mounting kit (Eases installation and facilitates adjustments due to guard misalignment)
AZS2305	Fail-to-Safe Timer (Please see page 80)
FWS1205B	Fail-to-Safe Standstill Monitor (Page 80)

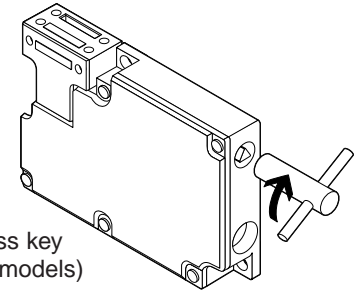

Solenoid-latch bypass key
(for locking via spring models)

MS AZM 161 ADJUSTABLE MOUNTING KIT

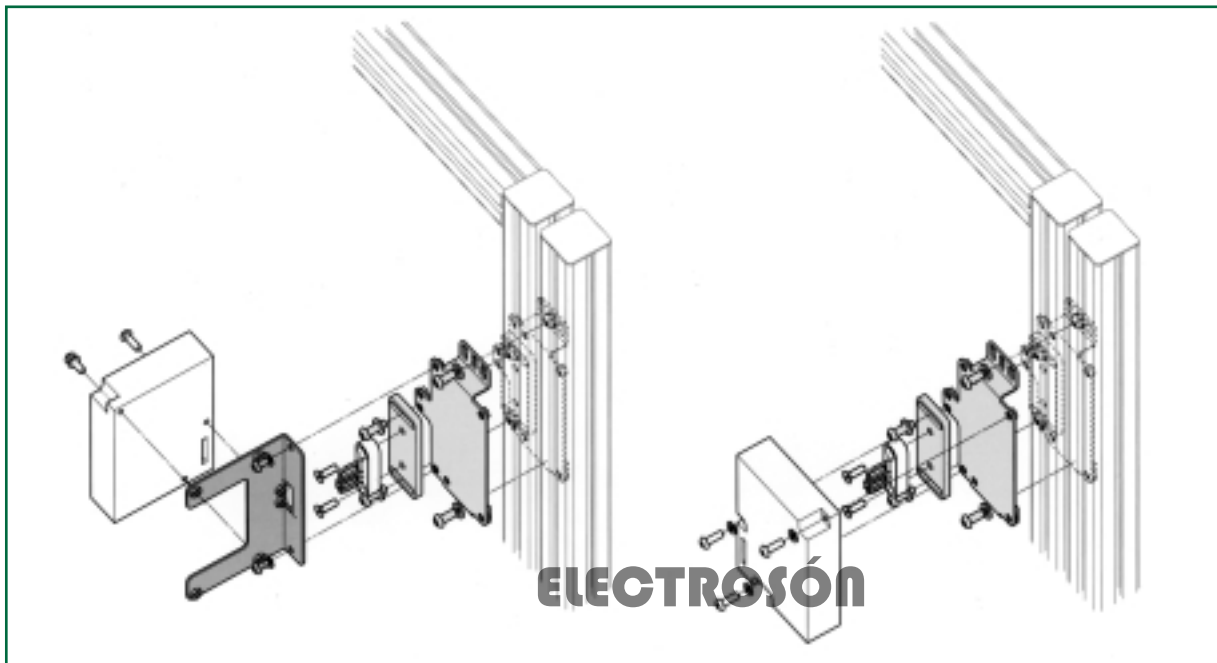

ELECTROSON

AZM161 TECHNICAL DATA

MECHANICAL SPECIFICATIONS

Housing	Glass-fibre reinforced self-extinguishing thermoplastic
Actuator Key	Stainless steel (defeat-resistant design)
Degree of Protection	IP67
Unlocked Holding Force	30N (7 pounds)
Travel for Positive-Break	8mm (0.315 inches)
Force to Reach Positive-Break	10N (Approx. 2.4 pounds)
Closing Force	Approx. 15 N (3.4 pounds)
Operating Temperature	-13°F to +104°F
Mechanical Life	1 million operations
Conformity to Standards	IEC 947-5-1 EN 60947-5-1 DIN VDE 0660-200 BG-GS-ET-15 UL CSA
Solenoid Locking Force	2,000N (440 pounds)
Key Return Force	0N
Minimum Closing Radius	5.9" (150mm) with B1 and B1E actuating key 3.7" (95mm) with B6 actuating key

ELECTRICAL SPECIFICATIONS

Contacts	Fine silver
Contact Configuration	Double-pole, double-break with electrically separated contact bridges
Contact Gap	2 x 2 mm (minimum)
Contact Rating	2A (230VAC)
Switching Action	Slow-action, positive-break NC contacts
Short Circuit Protection	Fuse 6A (time-delay)
Rated Insulation Voltage	250VAC
Rated Impulse Withstand Voltage	6kV
Type Terminals*	Screw terminals with self-lifting clamps for up to 13 AWG flexible stranded wire (2.5mm ²)
Available Solenoid Supply Voltages (Vs)	24VDC, 110VDC, 230VDC 24VAC/50Hz 115VAC/60Hz 230VAC/50Hz
Solenoid Power Consumption	10W (maximum)
Solenoid Duty Cycle	100%
Solenoid Pull-in Voltage	(0.85 to 1.1) Vs
Solenoid Drop-out Voltage	(0.2 to 0.75) Vs

*Optional cage clamp terminations available.
Please consult factory.

SWITCHING DIAGRAMS & CONTACT SCHEMATICS (Solenoid-mechanism not energized)

