



RE620



E650



RE620

INCREMENTAL ROTARY ENCODERS

Square Flange

- Incremental rotary encoders with or without zero pulse
- Pulses per revolution: 2 to 36000
- ABS or aluminium case (series RE - REV)
- Several configurations available

MECHANICAL VERSIONS

E620/E521

Body Ø: 58 mm
 Flange mm 63.5x63.5
 Centering mask Ø 31.75 mm
 Shaft Ø 6, 8, 9.52, 10 mm

E650/651

Body Ø: 58 mm
 Flange mm 63.5x63.5
 Centering mask Ø 50 mm
 Shaft Ø 6, 8, 9.52, 10 mm

Encoder series **E**: **ABS** plastic case
 Encoder series **RE**: **Aluminium** case
Pulses per revolution range: 2 to 12500
 Encoder series **REV**: **aluminium** case, **glass** disk
Pulses per revolution range: 1000 to 36000

MECHANICAL & ENVIRONMENTAL SPECIFICATIONS

• Materials: case shaft	ABS / aluminium (RE/REV) AISI 303 steel
• Weight	280 g ca / series RE/REV 400 g ca
• Shaft Ø	6, 8, 9.52, 10 mm
• Revolutions/minute	6000 continuous/10000 temporary*
• Starting torque	≤0,8 Ncm
• Inertia	≤25 g cm ²
• Max load	80 N axial/100 N radial
• Vibration resistance (10÷2000 Hz)	100 m/sec ²
• Shock resistance (11 ms)	50 G
• Protection degree	IP64 / optional IP65 with sealing ring*
• Operating temperature	-10 ÷ 70°C
• Stacking temperature	-20 ÷ 80°C

ELECTRICAL & OPERATING SPECIFICATIONS

• Pulse code	Incremental
• Pulses per revolution	2 ÷ 12500 series REV : 1000 ÷ 36000
• Zero reference pulse	one pulse/revolution
• Output signals	Two square waves 90° ±15° out of phase – Zero pulse width: 90°±15°
• Electronic outputs	push-pull, NPN open collector, 5Vdc or 8/24Vdc line driver signals protected against short circuits
• Supply voltage	5Vdc or 8/24Vdc - protection against polarity reversal
• Absorption	30÷80 mA max
• Max frequency	100/200 KHz
• Connections	Axial or radial cable 3 m long /1 m for line driver output Axial or radial MS connector, 7-pin/10-pin for line driver output*

*Max operating speed with IP65 sealing ring applied on the shaft: 3000 rpm

*The encoder configuration: zero pulse + line drive output +radial connector outlet can only be supplied with aluminium case (series **RE**)



RE620



E650



E620

CONNECTIONS

SIGNALS	Push Pull – Open Collector NPN			SIGNALS	Line Driver			
	7-pin connector	Cable colours			7-pin connector	Cable colours		
	<i>DIAGRAM 1</i>	<i>DIAGRAM 2</i>			<i>DIAGRAM 3</i>		<i>DIAGRAM 4</i>	
					without 0 pulse		with 0 pulse	
Out 1	A	C	White	Out 1	A	White	A	White
Out 2	B	E	Green	Out 2	B	Green	B	Green
Out Z	C	D	Brown	Out Z			C	Grey
+ Vdc	D	F	Red	+ Vdc	D	Red	D	Red
0V	F	A	Blue	0V	F	Blue	E	Red
Non-connected	E	B		Out 1 ₋	C	Brown	F	Blue
Non-connected	G	G		Out 2 ₋	E	Yellow	G	Brown
Earth			Shield	Out Z ₋			H	Yellow
				Non-connected	G		I	Pink
				Non-connected			J	Shield

ORDERING INFORMATION

E620	C	1000	8/24	R	6	PP	2
-------------	----------	-------------	-------------	----------	----------	-----------	----------

CONNECTION DIAGRAM
2 – 4

OUTPUT SIGNALS
PP Push-pull
OC NPN Open Collector
LD Line-driver

SHAFT Ø
6 - 8 - 9.52 - 10

CONNECTIONS POSITIONS
A Axial
R Radial

SUPPLY VOLTAGE
8/24 Vdc
5 Vdc

PPR
2 ÷ 12500 series E/RE
1000 ÷ 36000 series REV

CONNECTION OUTLET
- Connector
C Cable

TIPO
E620 – E650 Plastic case, no zero pulse, 2÷12500 ppr
E621 – E651 Plastic case, zero pulse, 2÷12500 ppr
RE620 – RE650 Aluminium case, no zero pulse, 2÷12500 ppr
RE621 – RE651 Aluminium case, zero pulse, 2÷12500 pp
REV620 – REV650 Custodia in alluminio, senza impulso zero, 1000÷36000 i/g
REV621 – REV651 Aluminium case, zero pulse, 1000÷36000 ppr

VARIATIONS ADMITTED WITHOUT NOTICE

Dimensional drawings available at
www.elap.it/eng/incremental-encoders/encoder-e620.html

E620 uscita serracavo
E620 cable outlet

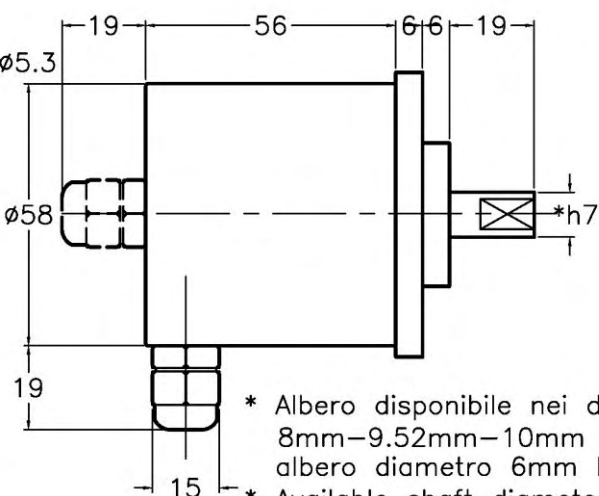
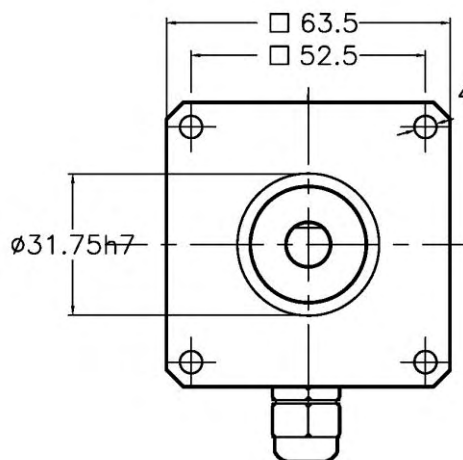

* Albero disponibile nei diametri
8mm-9.52mm-10mm
albero diametro 6mm lunghezza 10mm
* Available shaft diameters
8mm-9.52mm-10mm
shaft diameter 6mm length 10mm

E650 uscita connettore 7p
E650 10pin output connector

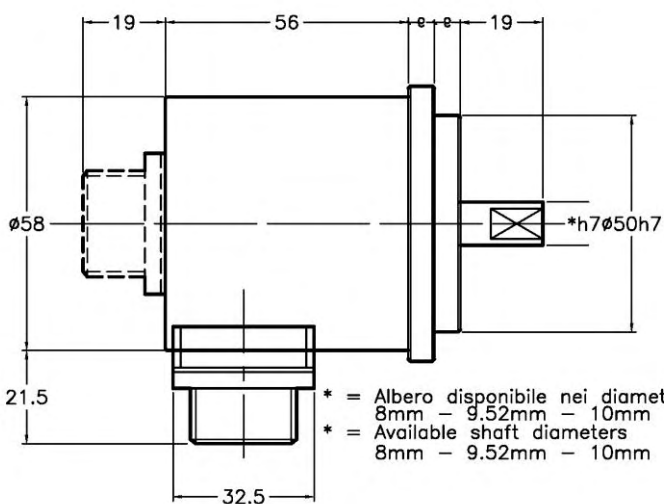
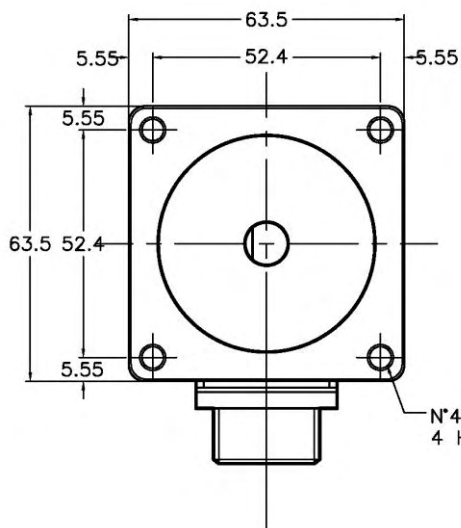

* = Albero disponibile nei diametri
8mm - 9.52mm - 10mm
* = Available shaft diameters
8mm - 9.52mm - 10mm

DIMENSIONS

RE620 uscita connettore 10p
RE620 10pin output connector

